

4pc 85556

ASSEMBLY INSTRUCTIONS

Rolling Garden Cart

ITEM# TC1852

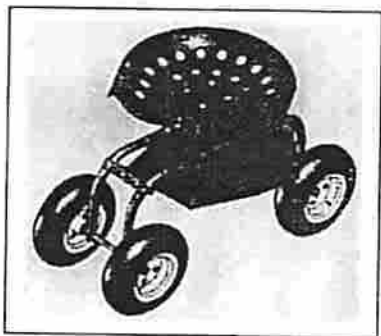

Part List

A: Frame 1pc 	B: Seat 1pc 	C: Wheel 4pc 	D: Tool Tray 1pc
E: Flat Plate 2pc 	F: Axle 2pc 	G: Seat Post 1pc 	

Hardware List

1: Cotter Pin 1pc 	2: Seat Screw 4pc 	3: Tray Screw 4pc 	4: Wheel Washer 8pc 		
5: Seat Washer 4pc 	6: Tray Washer 4pc 	7: Seat Hex Nut 4pc 	8: Tray Hex Nut 4pc 	9: Wheel Nut 4pc 	10: Frame Washer 1pc

Step 1 :

Remove Cotter Pin (1) and Frame Washer (10) already attached to Seat Post (G). Thread the Seat Post into the Frame (A) and replace Cotter Pin and Frame Washer.

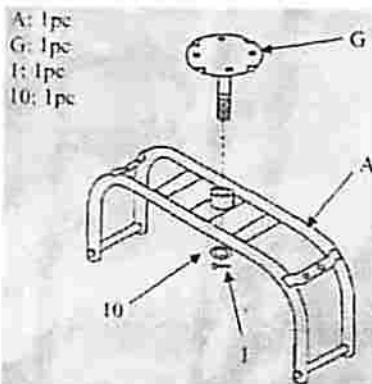

Step 3 :

Attach Tool Tray (D) to Frame (A) with Flat Plate (E), Tray Screw (3), Tray Washer (6) and Tray Hex Nut (8). Align the holes of Flat Plate (E) and Frame bracket with the holes of Tool Tray (D) lip. Frame bracket will mount on the frame itself lining holes with the tray. Note: Frame bracket comes pre-welded to frame.

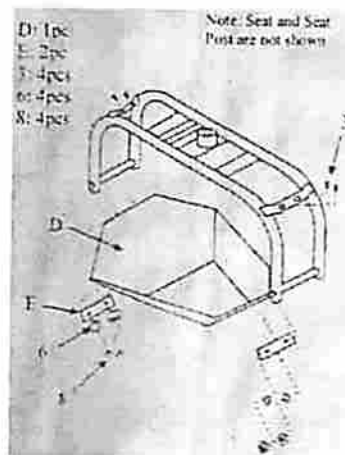

Step 2 :

Use Seat Screw (2), Seat Washer (5) and Seat Hex Nut (7) to attach Seat (B) to Seat Post (G).

B: 1pc
2: 4pcs
5: 4pcs
7: 4pcs

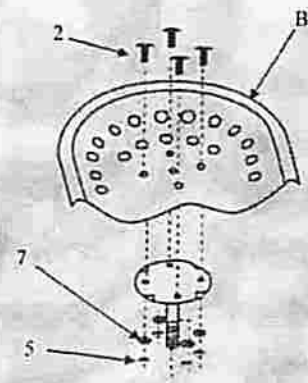

Step 4 :

Slide each Axle (F) through Main Frame (A). Slide Wheel Washer (4) on each side of each axle. Next slide Wheel (C) onto each side of axle, followed by another Wheel Washer (4) and Wheel Nut (9).

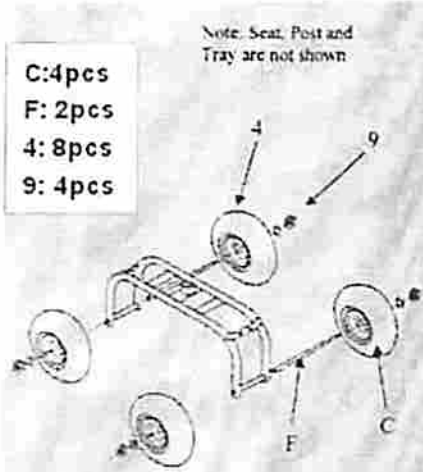

C: 4pcs
F: 2pcs
4: 8pcs
9: 4pcs







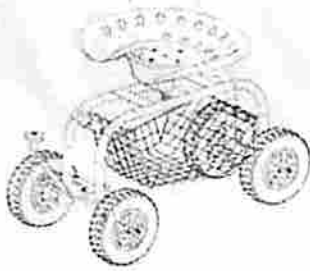

Note: Seat, Post and Tray are not shown

ASSEMBLY INSTRUCTIONS









Rolling Garden Cart



Part

 x1	 x1	 x1
 x1	 x1	 x4
 x1	 x1	 x1

Parts List

 x4	 x4	 x4	 x4
 x5	 x8	 x4	 x2

Step 1

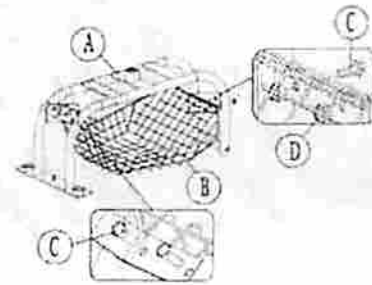

Step 2

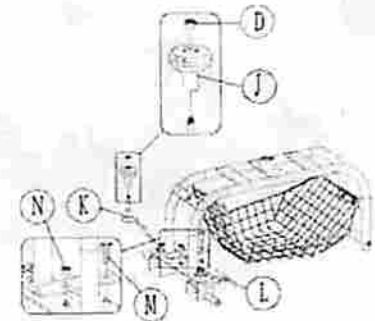

Step 3

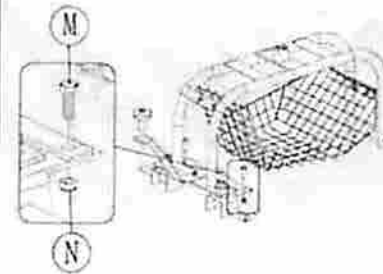

Step 4

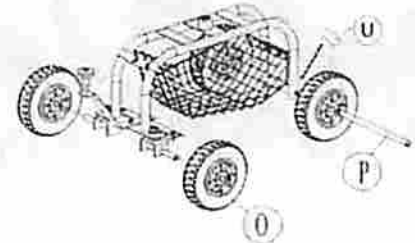

Step 5

